

MAKERA | CARVERA AIR

EXAMPLES GUIDE

MAKERA
BE A MAKER, SHAPE AN ERA!

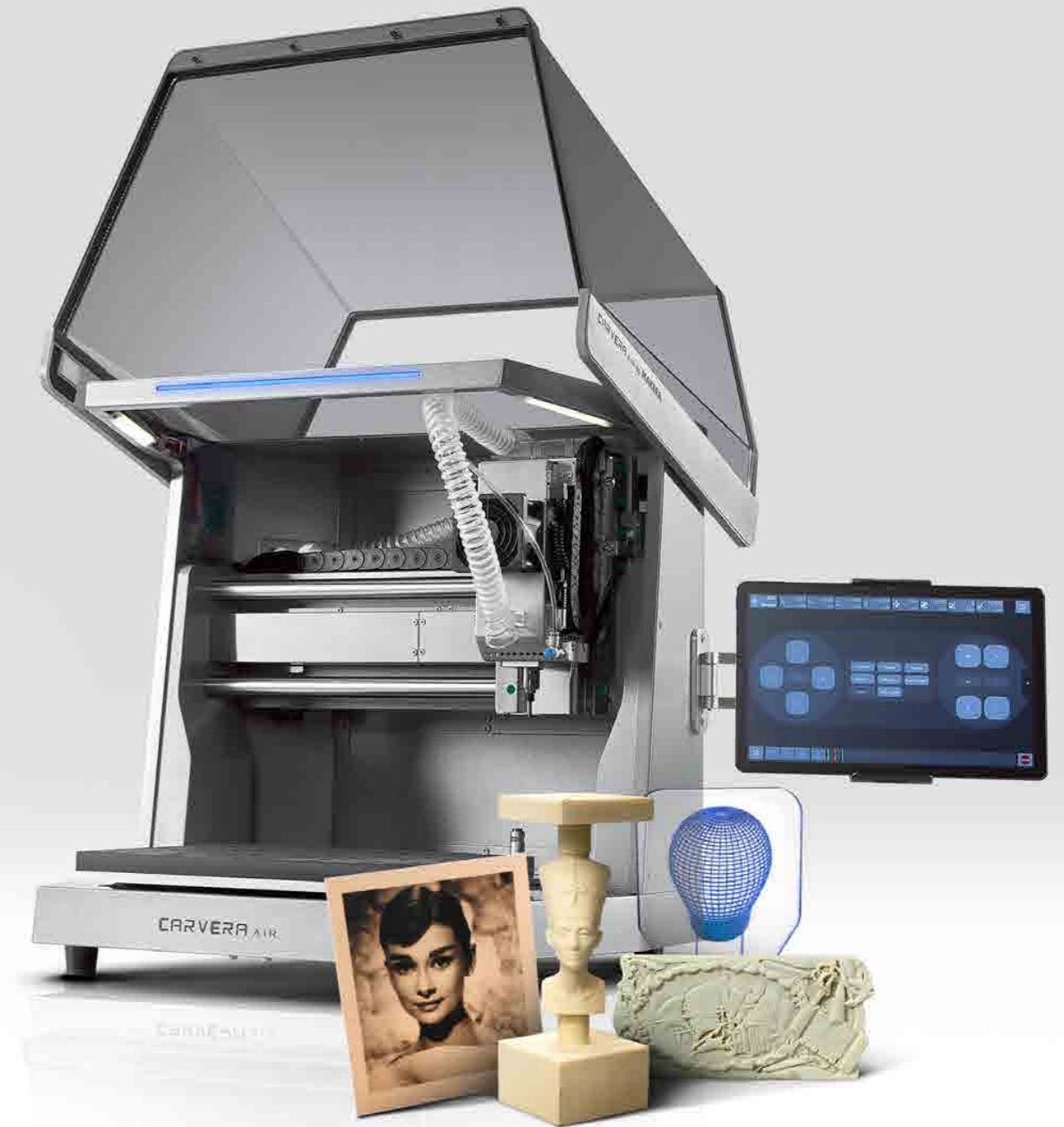

www.makera.com

01 ^{/04}

LED light

Circuit 6

Base 14

Display board 16

Touch switch 19

Assembly 21

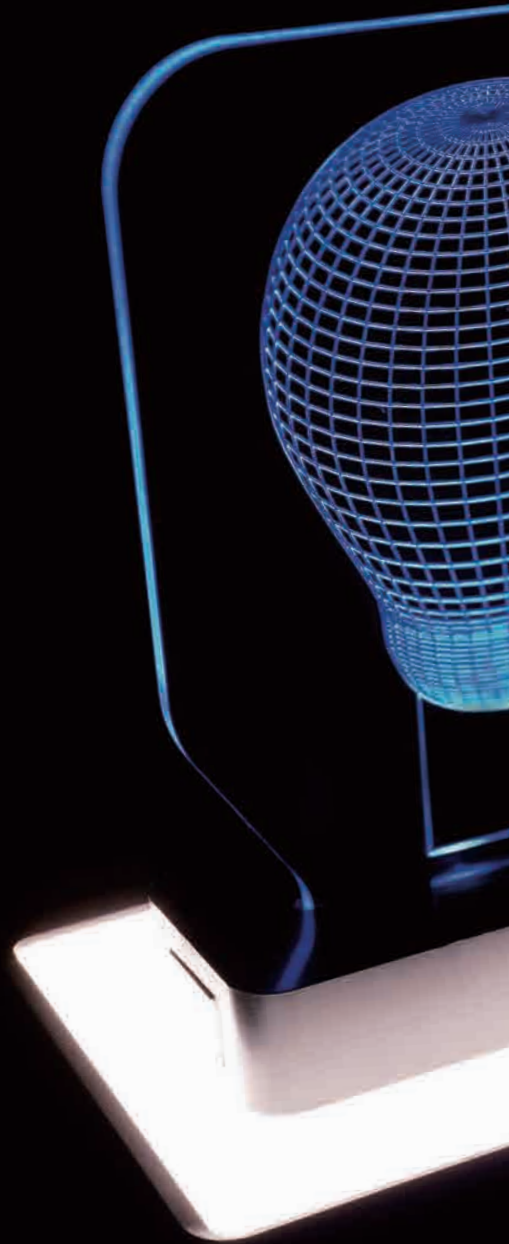

02 ^{/22}

Laser engraving



03 ^{/26}

Three-axis relief



04 ^{/30}

4th-axis relief



Introduction

Practice is the most direct and effective learning method. We provide a series of machining samples, materials and tools to make you familiar with the functions and procedures of using Carvera Air to do delicate works.

With streamlined capabilities, Carvera Air greatly simplifies the machining process. However, we still recommend reading the Carvera Air instruction manual carefully before start using it. This will ensure that you get a quick knowledge of Carvera Air and avoid basic misoperations.

For specifications and more information, please visit our official website:
www.makera.com

If you have any problems with Carvera Air, please contact us directly:
support@makera.com

Also, join in the Facebook group to discuss and share your experience with other Carvera Air users:
www.facebook.com/groups/carveraair

We will keep updating video tutorials and sample making cases on the YouTube channel, do not forget to subscribe!
www.youtube.com/c/Makera



Preparation

To protect the matching bed MDF board from being cut, we provide you with a thin Spoil Board, featuring the same hole positions as the desktop density board, to facilitate the fixing of workpieces. You can secure it to the desktop before machining.

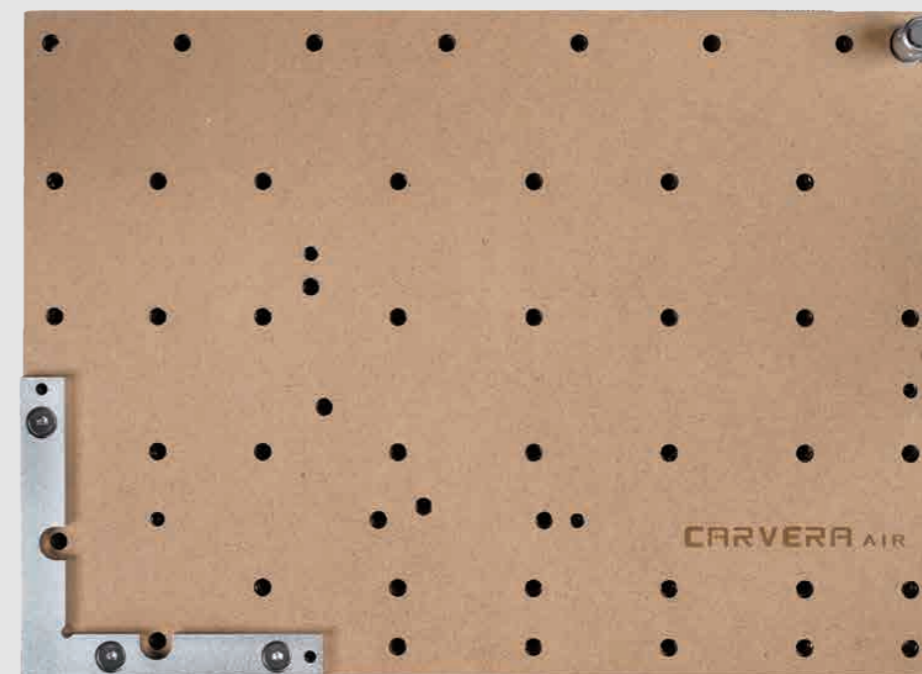

The tools used in this Example Guide can all be found in the Tool kits box. See the corresponding tool name and number as follows.



Tool 1: Spiral 'O' Single Flute Bit -1/8"Shank-3.175mm*25mm



Tool 2: Single Flute Engraving Bit -1/8" Shank_30°* 0.2mm



Tool 3: TiN Coating Corn Bit-1/8"Shank-0.8mm*5.5mm



Tool 4: Spiral 'O' Single Flute Bit for Metal-1/8"Shank-3.175mm*12mm



Tool 5: UV Solder Mask Removal Tool -1/8" Shank (Optional)

CARVERA AIR

LED light

01

01



LED light

The LED light in this example consists of four parts: the circuit, the base, the display light board, and the touch switch, which shows the comprehensive capabilities of the Carvera Air.

With Carvera Air, you can significantly accelerate the process from design to prototype, and even to commercial products.

Circuit



Material preparation

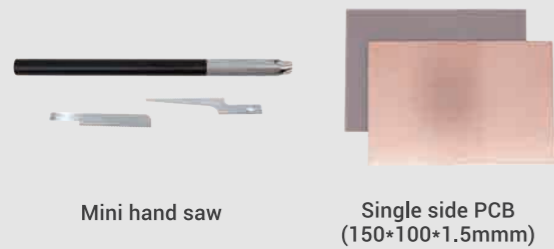

Mini hand saw

Single side PCB (150*100*1.5mm)

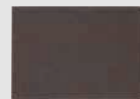

Sand block



optional

PCB Fabrication Pack



UV cure lamp



UV curable solder mask paint



UV solder mask removal tool



UV solder mask roller

Machining process :

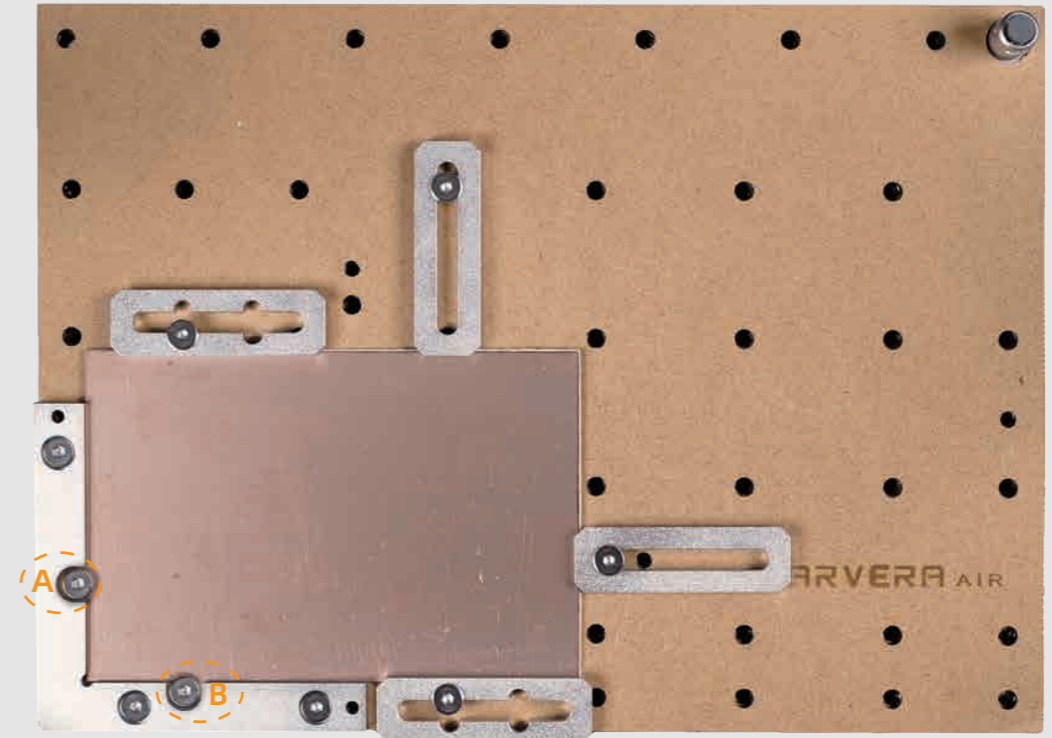

1. Fix the PCB and the wasteboard to the worktable, as shown in the figure. Position them adjacent to the L-bracket at anchor point 1. Ensure points "A" and "B" are also fastened with screws.

Note: Use the edge of the top clamps to fix the PCB and leaves sufficient space for dust collection and milling.

Note: The PCB board may deform after being stored for a long time. It is recommended to flatten the PCB before machining to increase accuracy. Better use some double-sided tape between the wasteboard and the bed / PCB for further consistency.

2. Make sure the used milling bits are ready: No.2-30°0.2mm V-bit, No.3-0.8mm corn bit, No.5-UV solder mask removal bit (Optional, when making a UV-soldermasked PCB only.)

3. Turn on the power and wait for the automatic homing to complete.

4. Open the control software and connect to Carvera Air (please read Carvera Air instruction manual for detailed steps.)

Circuit

5. Open the Root->Examples->LED folder under the Remote directory and select the machining file. If you bought the PCB pack and want to use the UV solder mask, please turn to the Use UV solder mask section; otherwise, continue the No UV solder mask section.

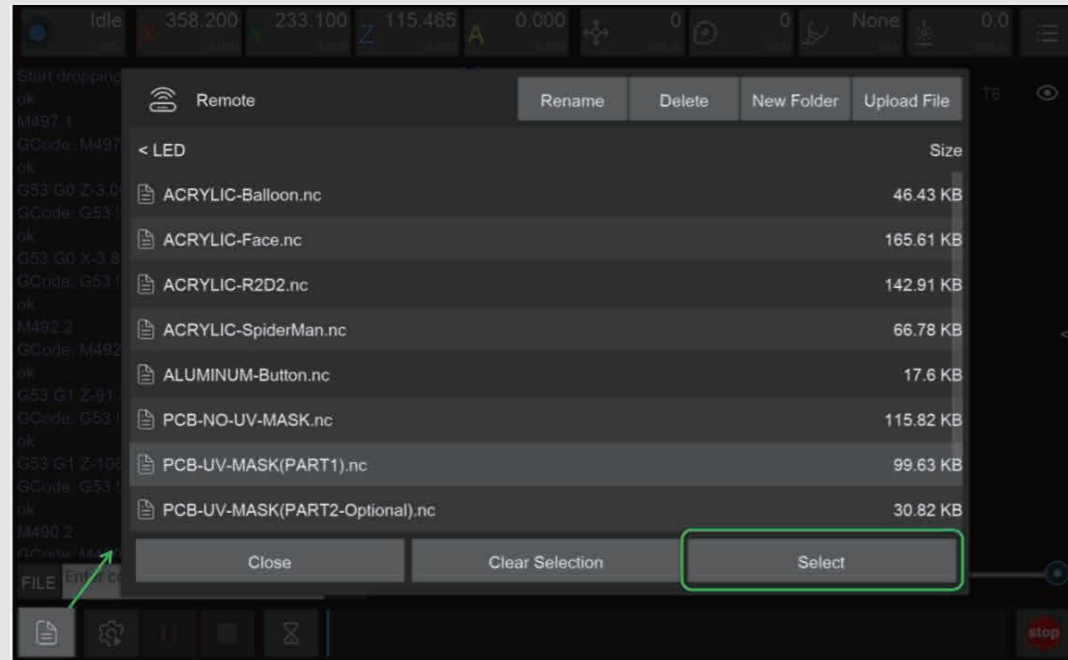

2. Open the task configuration and operation dialog box.
3. Set working coordinate to X offset 15, and Y offset 10 relative to anchor 1.
4. Check the "Scan Margin" option.
5. Check the "Auto Leveling" option, set the number of X detection points to 5, Y to 5, and the detection height to 2.
6. Check the configuration and click Run, change the tools according to the controller software's prompt. The tools that need to be replaced for this task are: the wired probe, Tool #2, and Tool #3.

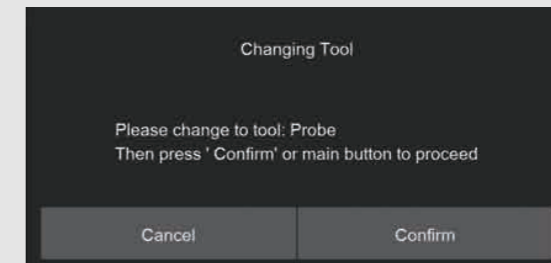

7. You can move the machine to the clearance position after the operation is completed to reduce the interference to subsequent operations.

★ No UV solder mask

1. Select the "PCB-NO-UV-MASK.nc" files to automatically run the tasks of PCB isolation, area cleaning, drilling and cutting contours.

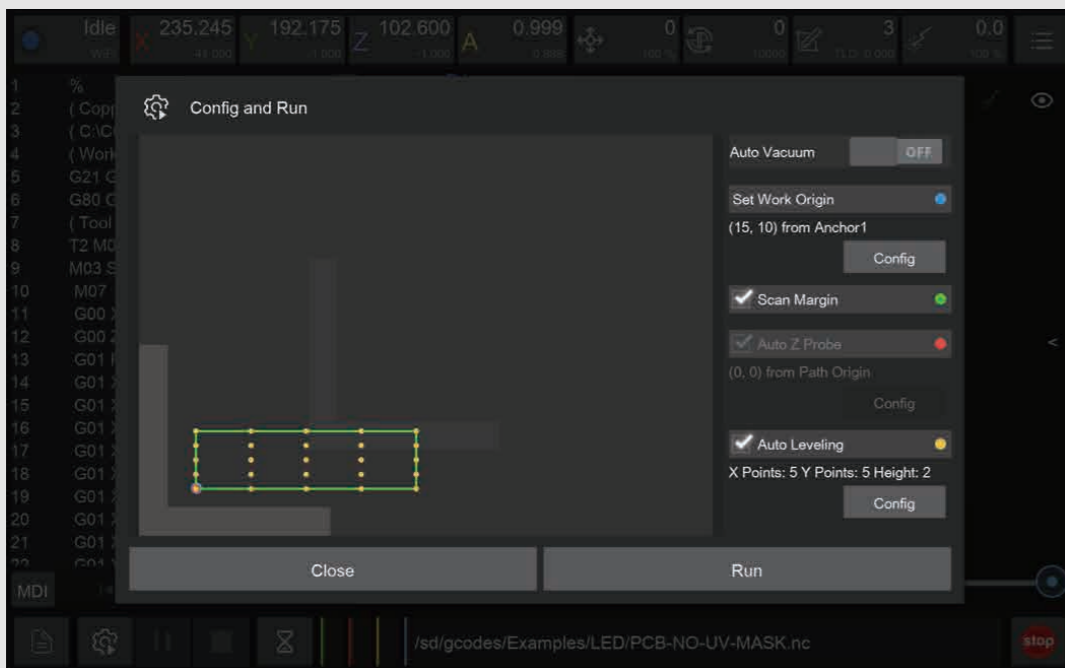

8. Take out the PCB board and cut off the tabs with the handsaw in the accessory kit.

Circuit

★ Use UV solder mask (If you bought the PCB pack)

● Machining step 1: PCB isolation and area cleaning

1. Select the "PCB-UV-MASK (PART1).nc" file.
2. Open the task configuration and operation dialog box.(The figure is the same as the first step of not using the UV solder mask)
3. Set working coordinate to X offset 15, and Y offset 10 relative to anchor 1.
4. Check the "Scan Margin" option.
5. Check the "Auto Leveling" option, set the number of X detection points to 5, Y to 5, and the detection height to 2.
6. Check the configuration according to the figure above and click Run, change the tools according to the controller software's prompt. (Please refer to Item 6 on Page 9)
7. You can move the machine to the clearance position after the operation is completed to reduce the interference to subsequent operations. (Please refer to Item 7 on Page 9)

● Machining step 2: Apply UV solder mask

1. Use the sanding block in the accessory kit to polish the PCB surface.
2. Use the roller to apply a thin layer of UV solder mask evenly.
3. Put the UV lamp above the PCB and wait for the UV layer solid.
4. Clean extra solder mask on the roller and other parts using alcohol wipes.

Note: Apply less UV solder mask first, increase later, its hard to clean up if apply too much. The curing time will varies with different UV solder mask and different UV lights. Please wait until the solder mask is completely solid.

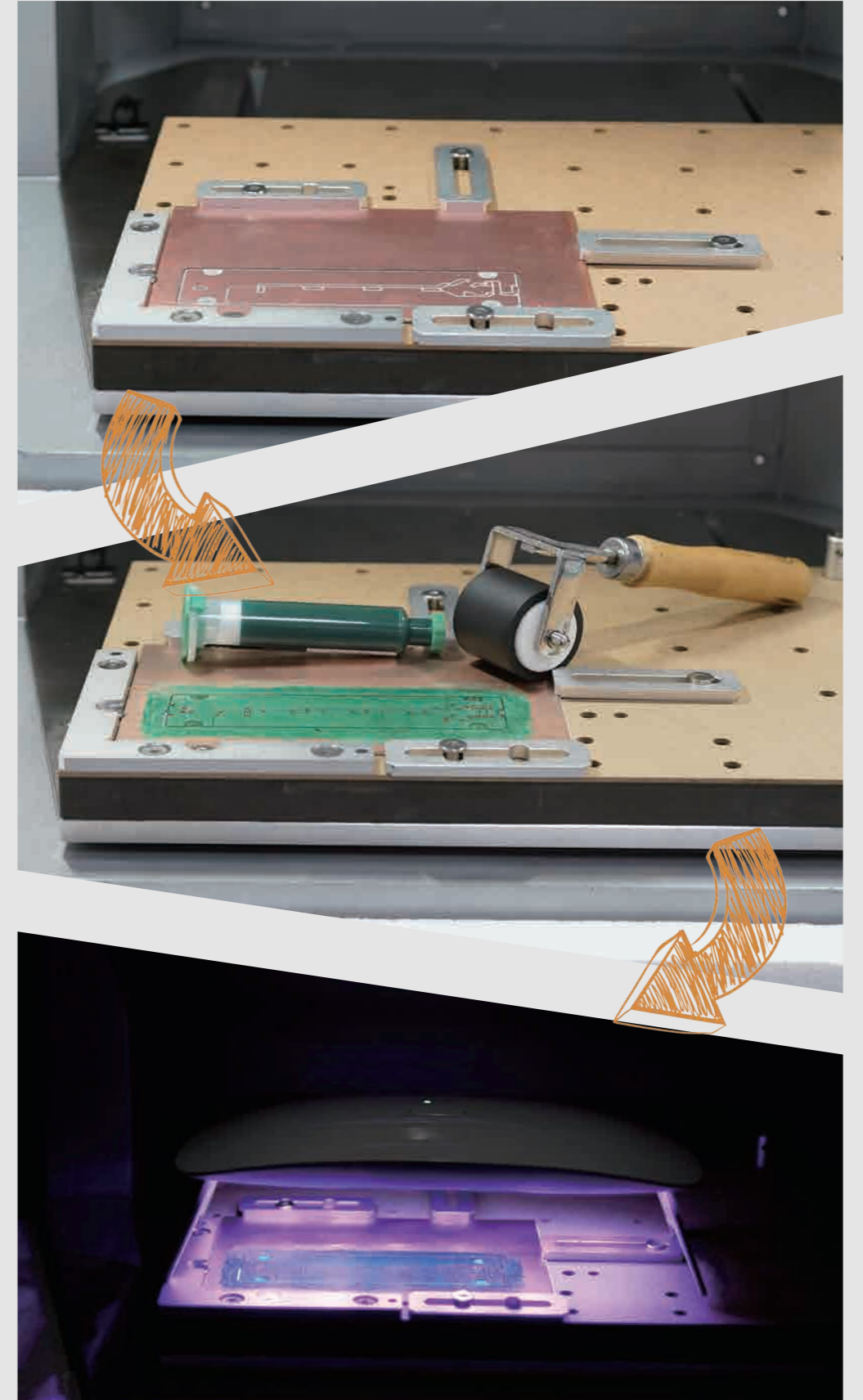

Circuit

• Machining step 3: Remove UV solder mask, drilling and cutting contours

1. Select the "PCB-UV-MASK (PART2).nc" file.
2. Open the task configuration and operation dialog box (the automatic detection has been completed in step 1, no need to redo here)
3. Uncheck "Scan Margin" option.
4. Uncheck "Auto Z Probe" option.
5. Uncheck "Auto Leveling" option.
6. Check the configuration according to the figure above and click Run, change the tools according to the controller software's prompt. (Please refer to Item 6 on Page 9)
7. You can move the machine to the clearance position after the operation is completed to reduce the interference to subsequent operations. (Please refer to Item 6 on Page 9)
8. Take out the PCB board and cut off the remaining tabs with the handsaw in the accessory kit. Flatten the edges using the sanding block.

Base part



Material
preparation

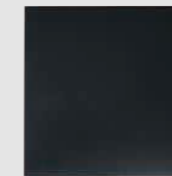

ABS Plastic board
(150*150*20mm)



Mini hand saw

Base part

Machining process:

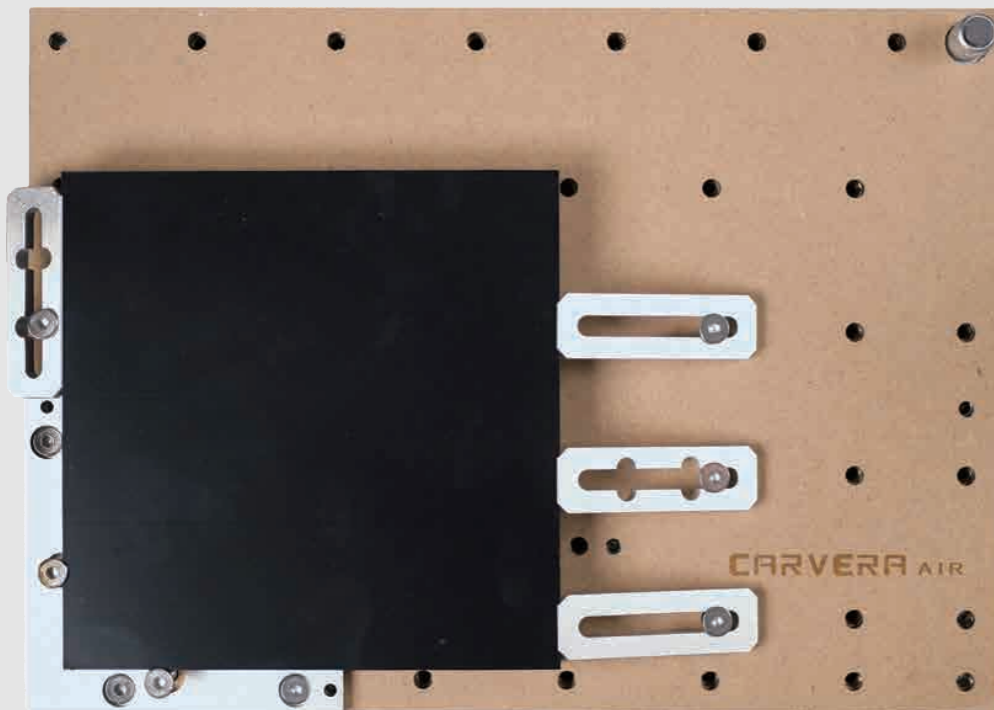

1. Fix the ABS plastic board and the wasteboard to the table as shown in the figure. Align it to the L-bracket at anchor point 1.

2. Make sure the used milling bits are ready. No.1-3.175*25mm single flute spiral bit, No.2-30°0.2mmV-bit.

3. Turn on the power and wait for the automatic homing to complete.

4. Open the control software and connect to Carvera Air (please read Carvera Air instruction manual for detailed steps)

5. Open Root->Examples->LED in the remote directory. Select "ABS-Base.nc" machining file.

6. Open the task configuration and operation dialog box

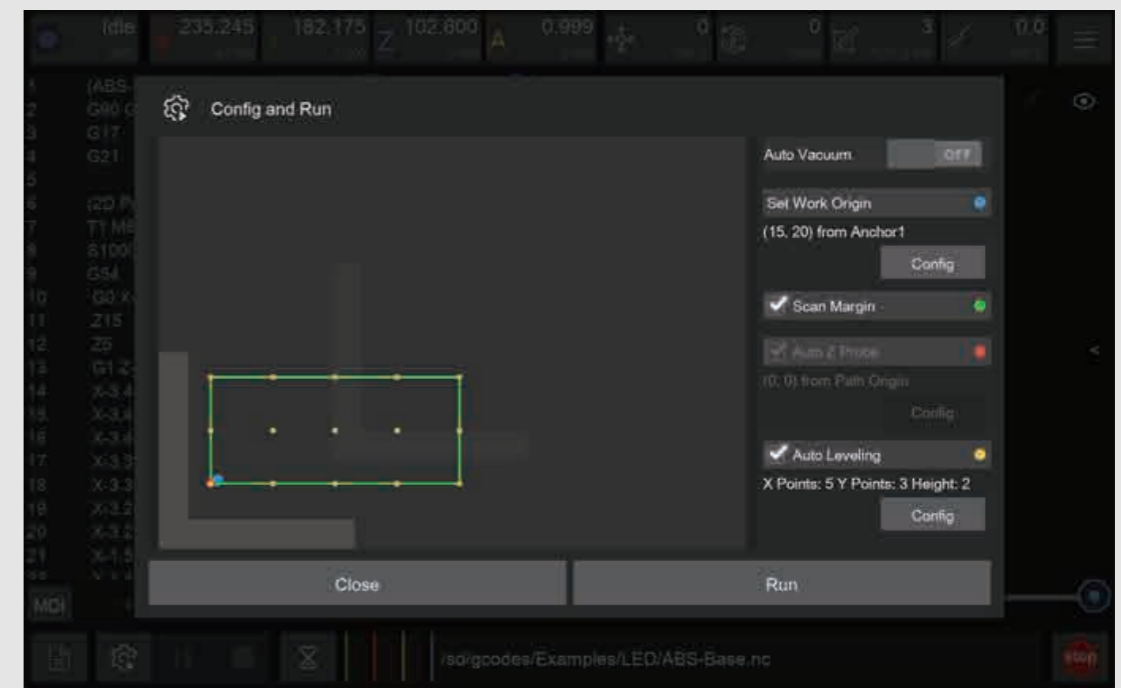

7. Set working coordinate to X offset 15, and Y offset 20 relative to anchor 1.

8. Check the "Scan Margin" option.

9. Check the "Auto Leveling" option, set the number of X detection points to 5, Y to 3, and the detection height to 2.

10. Check the configuration according to the figure above and click Run, change the tools according to the controller software's prompt. (Please refer to Item 6 on Page 9)

11. You can move the machine to the clearance position after the operation is completed to reduce the interference to subsequent operations. (Please refer to Item 7 on Page 9)

12. Use a vacuum to clean the table, take out the ABS board and use the handsaw in the accessory kit to carefully remove the tabs.

Display board



Material
preparation



Acrylic plate
(150*180*4mm)

Machining process :

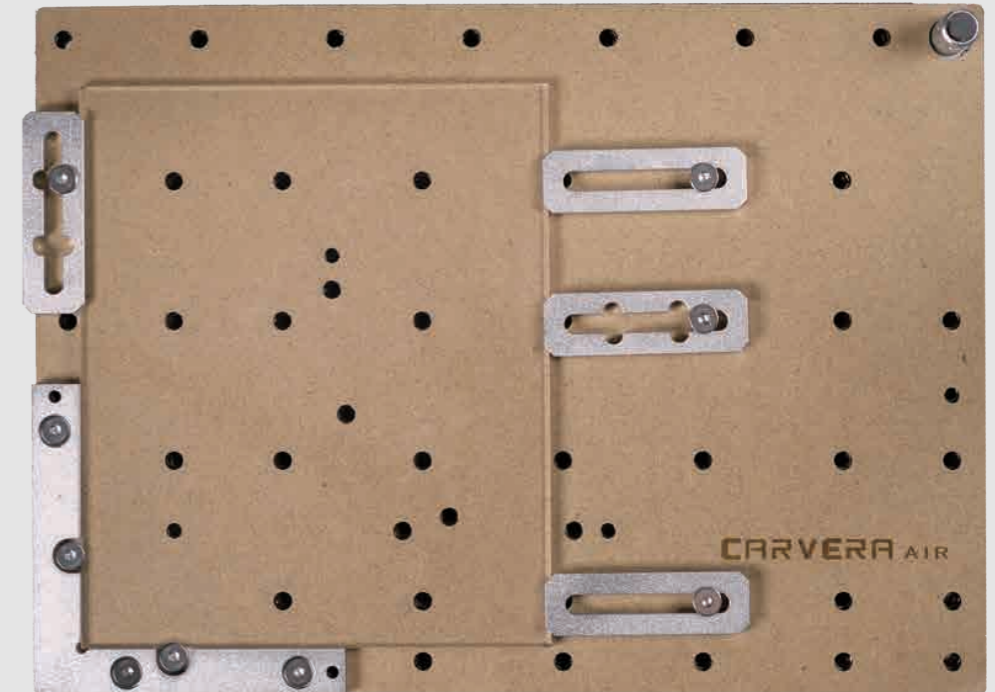

1. Remove the protective film on the top. Fix the acrylic board and the wasteboard to the table, as shown in the figure. Align it to the L-bracket at anchor point 1.
2. Make sure the used milling bits are ready. No.1-3.175*25mm single flute spiral bit, No.2-30°0.2mmV-bit.
3. Turn on the power and wait for the automatic homing to complete.
4. Open the control software and connect to Carvera Air (please read Carvera Air instruction manual for detailed steps)
5. Open Root->Examples->LED in the remote directory. Select the "ACRYLIC-XXXX.nc" file. Here we provided 5 pictures for you. You can choose the one of your preference.
6. Open the task configuration and operation dialog box.

Display board

7. Set working coordinate to X offset 15, and Y offset 25 relative to anchor 1.
8. Check the "Scan Margin" option.

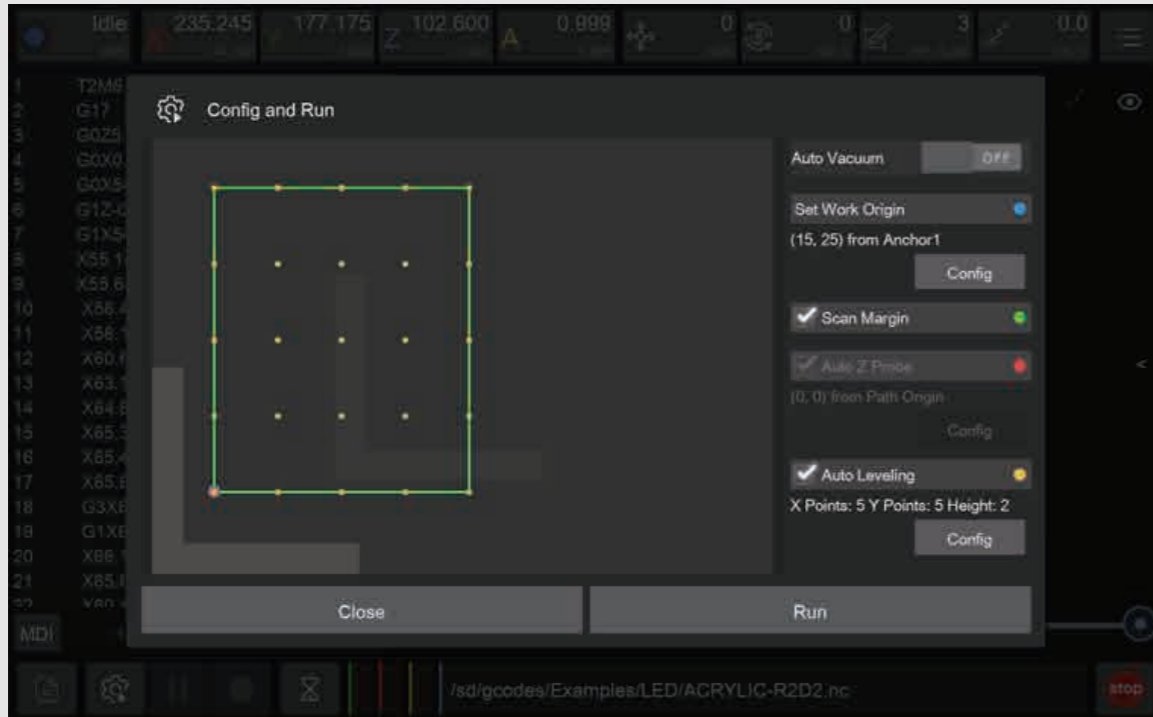

9. Check the "Auto Leveling" option, set the number of X detection points to 5, Y to 5, and the detection height to 2.
10. Check the configuration according to the figure above and click Run, change the tools according to the controller software's prompt. (Please refer to Item 6 on Page 9)
11. You can move the machine to the clearance position after the operation is completed to reduce the interference to subsequent operations. (Please refer to Item 7 on Page 9)
12. Use a vacuum to clean the worktop and remove the acrylic board.
13. Break the acrylic board by aligning the V-groove with an edge of a table.

Touch switch



Machining process :

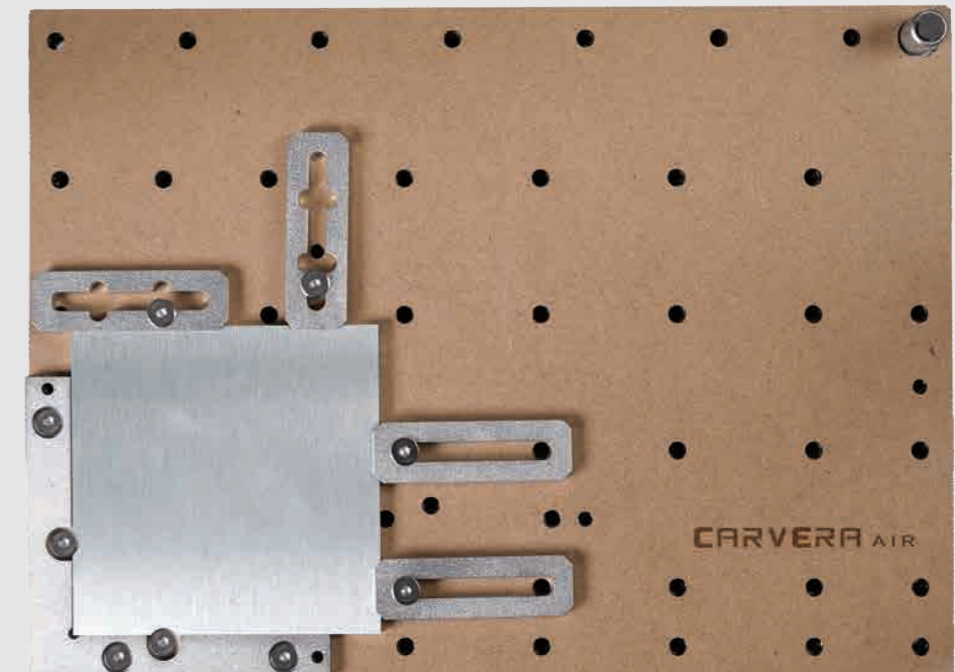

Touch switch

1. Fix the aluminium alloy board and the wasteboard to the table, as shown in the figure. Align it to the L-bracket at anchor point 1.
2. Make sure the used milling bits are ready. No.4-3.175*12 single flute spiral bit for metal.
3. Turn on the power and wait for the automatic homing to complete.
4. Open the control software and connect to Carvera Air (please read Carvera Air instruction manual for detailed steps)
5. Open Root->Examples->LED in the remote directory. Select the "ALUMINUM-Button.nc" file.
6. Open the task configuration and operation dialog box

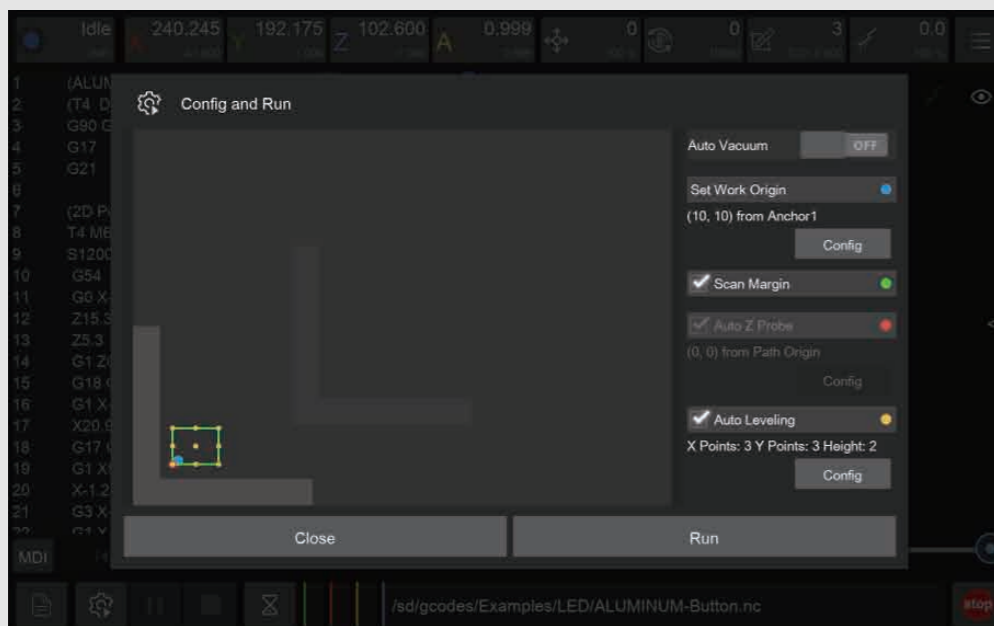

7. Set working coordinate to X offset 10, and Y offset 10 relative to anchor 1.
8. Check the "Scan Margin" option.
9. Check the "Auto Leveling" option, set the number of X detection points to 3, Y to 3, and the detection height to 2.
10. Check the configuration according to the figure above and click Run, change the tools according to the controller software's prompt. (Please refer to Item 6 on Page 9)
11. You can move the machine to the clearance position after the operation is completed to reduce the interference to subsequent operations. (Please refer to Item 7 on Page 9)
12. Use a vacuum to clean the worktop, remove the board and use the handsaw in the accessory kit to carefully remove the tabs.

LED lamp assembly

Solder PCB (Optional)

We provide a soldered PCB for your direct use. If you want to make your own, please refer to our soldered PCB board for components choosing and placement.

Assembly



1. Glue the aluminium alloy touch button to the side of the base.
2. Fix the PCB board to the bottom of the base with 4 screws.
3. Insert the acrylic display board into base.
4. Plug Type-C USB cable and the assembly is finished.
5. You can adjust the brightness and turn on/off the light by touching the aluminum button.

02

CARVERA AIR

Laser engraving

02

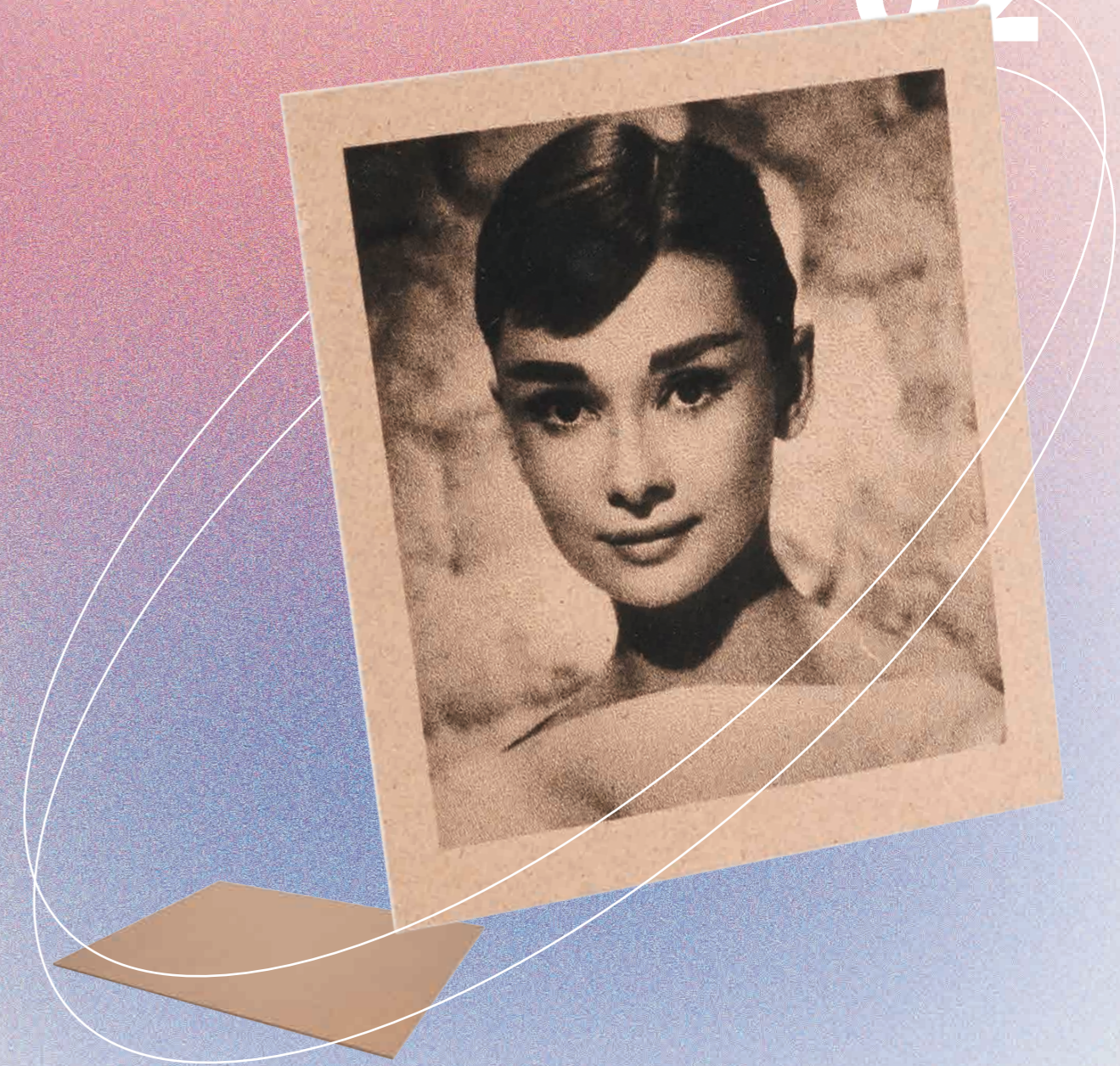

Laser engraving

Laser engraving is an auxiliary function in Carvera Air. We chose a 5W laser for mainly engraving the material, not for cutting. This case shows how to use the laser function to engrave pictures as black and white photos.

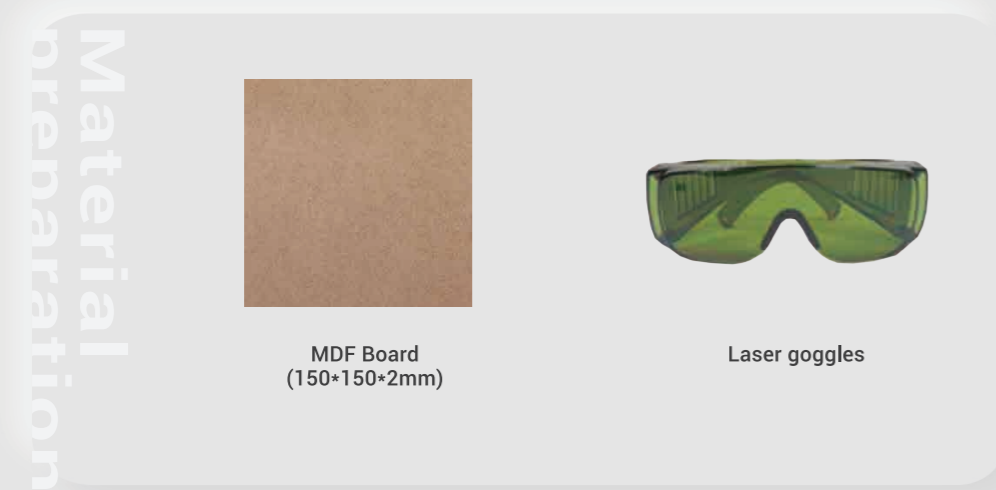

Note: Refer to the relevant sections in the instruction manual for guidance on how to install the laser module.

Note: Before engraving, ensure you are wearing proper eye protection and in a well ventilated space.

Machining process:

1. Secure the 150x150x2mm MDF to the bed, aligning it with the L-bracket at anchor point 1, as shown in the illustration below.



2. Turn on the power and wait for the automatic homing to complete.

3. Open the control software and connect to Carvera Air (please read Carvera Air instruction manual for detailed steps)

4. Open Root->Examples->Laser in the remote directory. Select the "AudreyHepburn.nc" file.

5. Open the task configuration and operation dialog box

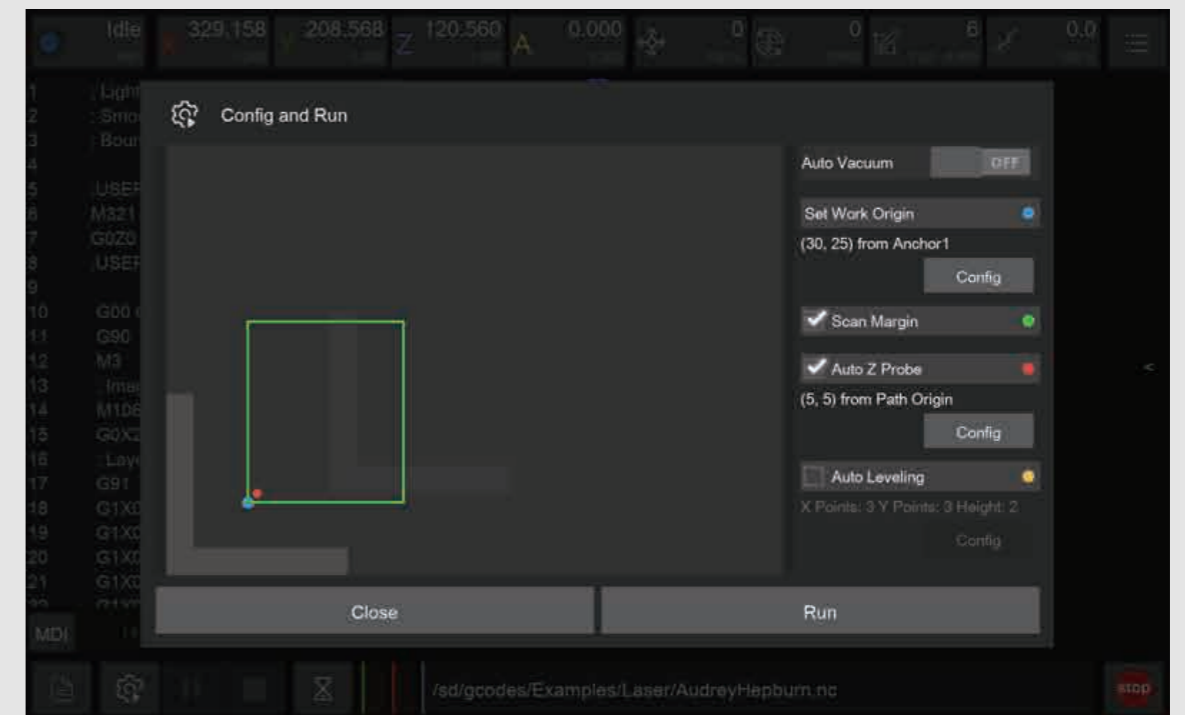

6. Set working coordinate to X offset 30, and Y offset 25 relative to anchor 1.

7. Check the "Scan Margin" option.

8. Check the "Auto Z Probe" option, set the probe point to X offset 5, Y offset 5 relative to Path Origin.

9. Uncheck the "Auto Leveling" option (Because laser engraving has a high tolerance for flatness, no need for leveling).

10. Check the configuration according to the figure above and click Run, change the tools according to the controller software's prompt. (Please refer to Item 6 on Page 9)

11. You can move the machine to the clearance position after the operation is completed to reduce the interference to subsequent operations. (Please refer to Item 7 on Page 9)

12. Remove the MDF.

03

CARVERA AIR

Three-axis relief

03

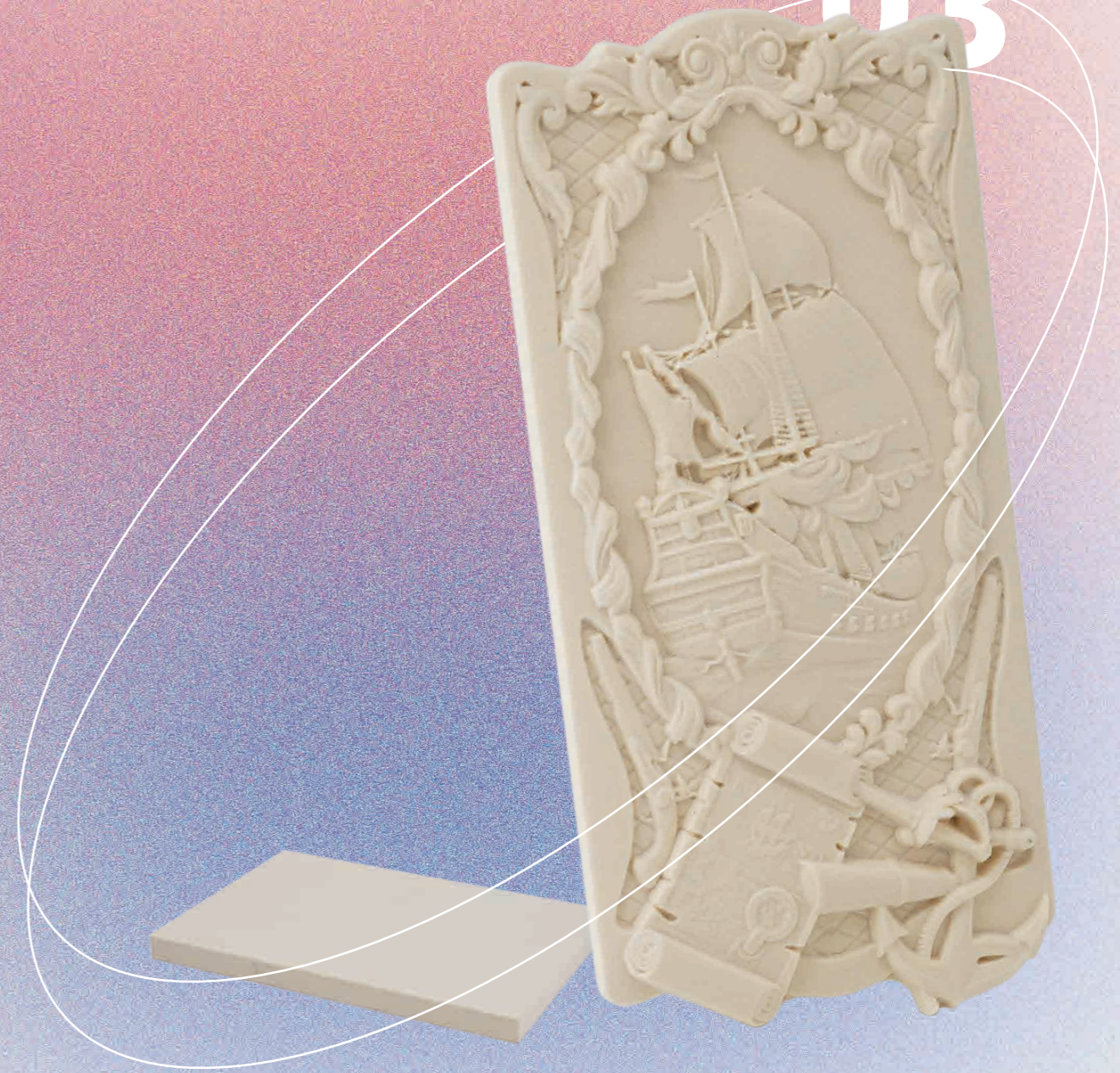

Three-axis relief

This case demonstrates how to use Carvera Air to perform roughing and finishing steps for machining a relief, offering a straightforward approach to creating intricate craftwork.

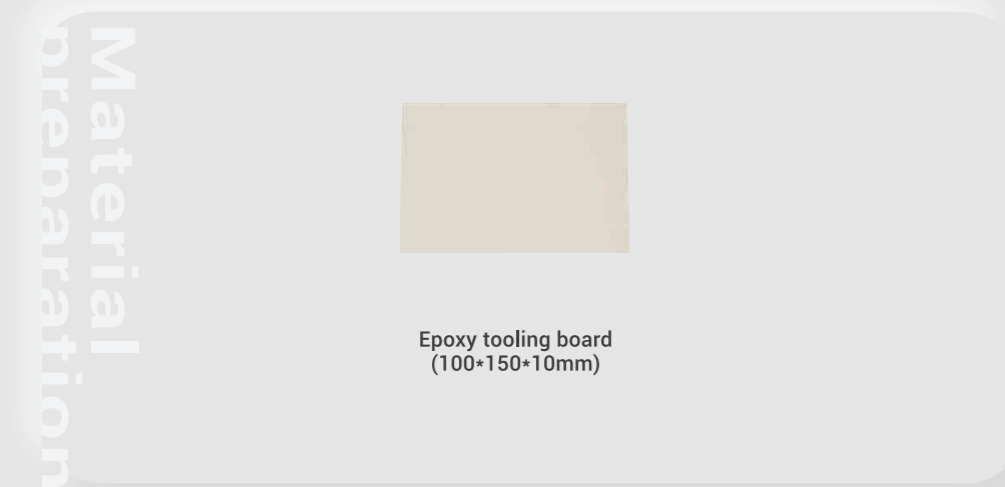

Machining process:

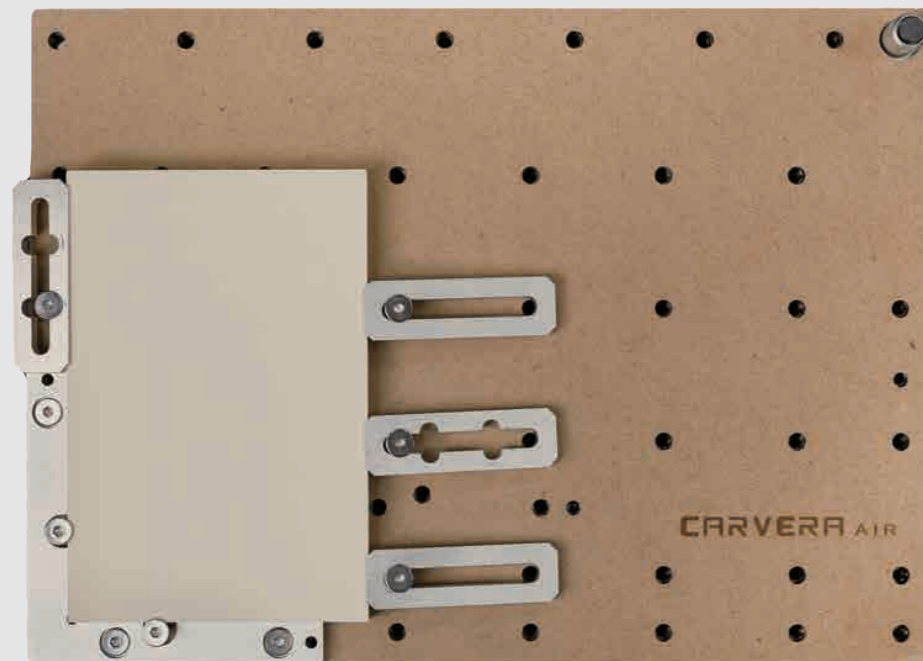

1. Fix the Epoxy Tooling Board and the wastebord to the table as shown in the figure. Align it to the L-bracket at anchor point 1.

2. Make sure the used milling bits are ready. No.1-3.175*25mm single flute spiral bit, No.2-30°0.2mmV-bit.
3. Turn on the power and wait for the automatic homing to complete.
4. Open the control software and connect to Carvera Air (please read Carvera Air instruction manual for detailed steps)
5. Open Root->Examples->Relief in the remote directory. Select the "PirateShip.nc" file.
6. Open the task configuration and operation dialog box.

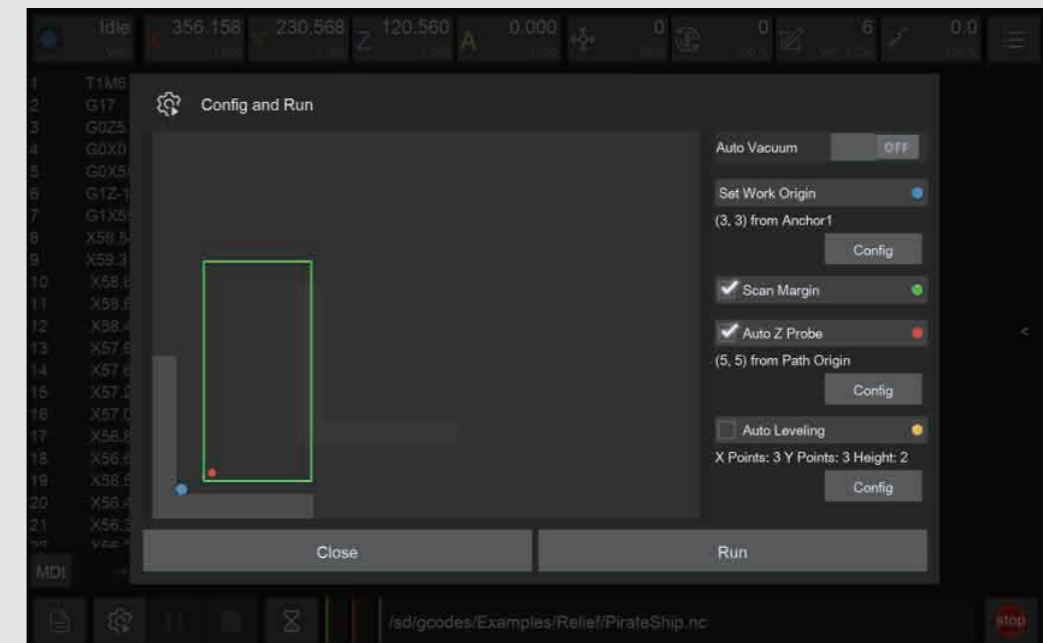

7. Set working coordinate to X offset 3, and Y offset 3 relative to anchor 1.
8. Check the "Scan Margin" option.
9. Check the "Auto Z Probe" option, set the probe point to X offset 5, Y offset 5 relative to Path Origin.
10. Uncheck "Auto Leveling". (Because the material's surface will be milled to a certain height, no need for automatic levelling detection)
11. Check the configuration according to the figure above and click Run, change the tools according to the controller software's prompt. (Please refer to Item 6 on Page 9)
12. You can move the machine to the clearance position after the operation is completed to reduce the interference to subsequent operations. (Please refer to Item 7 on Page 9)
13. Remove the epoxy tooling board and use the handsaw in the accessory kit to take out your work.

04

CARVERA AIR

4th-axis relief

04

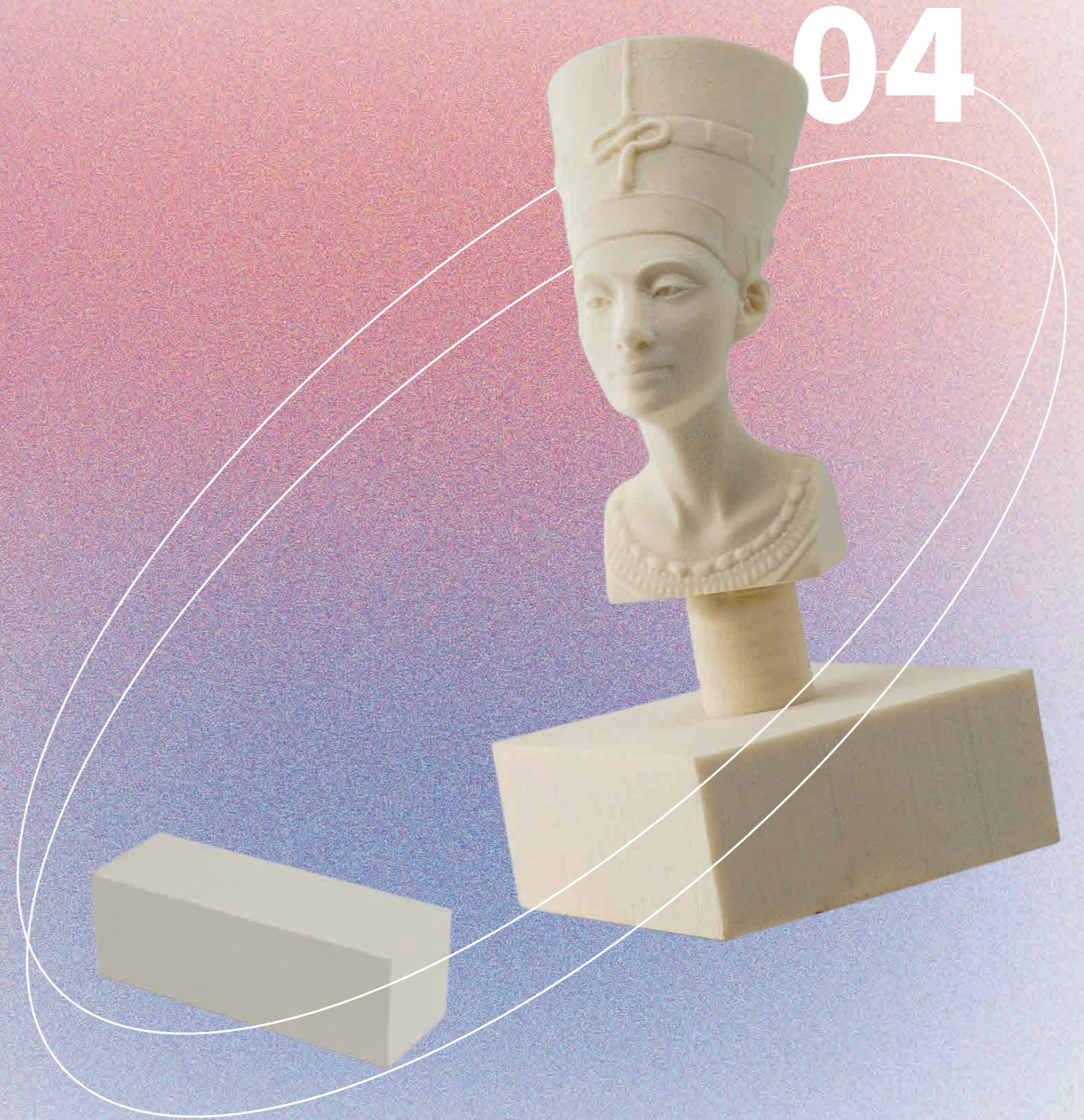

4th-axis relief

This example shows you how to use Carvera Air's rotary axis to machine a 3D object. We don't use dust collection for rotary axis machining, so we split the roughing and finishing process into two jobs. You should clean the dust between the two steps.

The Nefertiti sample model in this guide was from Thomas Roussel - Thingiverse: @lecaramel.

Note: Please read the instruction manual carefully to understand how to install and use the 4th axis.

Note: Some of the parameters for 4-axis and 3-axis machining are different: The 3-axis can be positioned using anchor point 1 or anchor point 2, while the Y-axis position of the 4-axis is fixed, and the X-axis is positioned relative to the right edge of the headstock.

Note: We don't use auto-leveling for 4-axis machining, and the auto z probe position is fixed.

Note: We don't use dust collection for 4-axis machining. Please remove the dust shoe.

Material
preparation

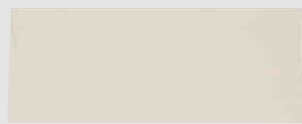

Epoxy tooling board
(35*35*100mm)

Machining process :

1. Plug in the cable and Install the rotary axis. (Please read the Carvera Air instruction manual for using the rotary axis) If your Carvera Air is on, please power off the machine first before installation.

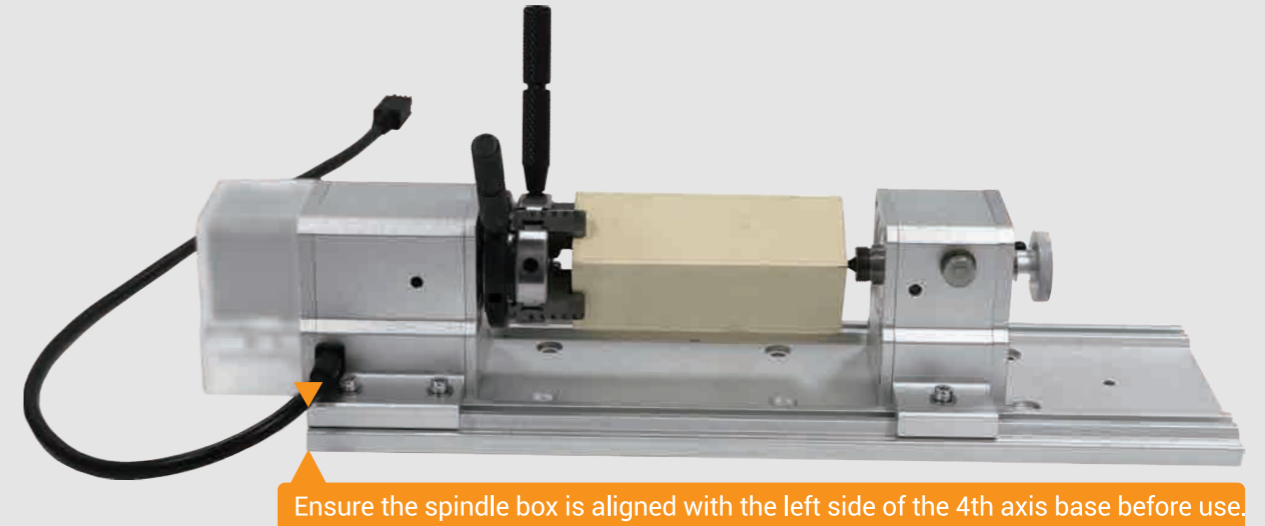

2. Fix the Epoxy Tooling Board to the rotary axis, let the corner direction up and down.

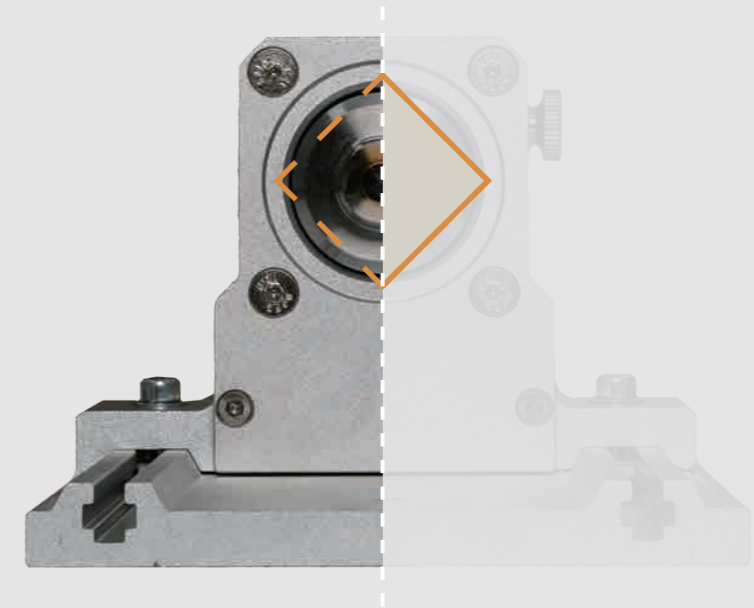

3. Make sure the used milling bits are ready . No.1-3.175*25mm single flute spiral bit, No.2-30°0.2mmV-bit.

4. Turn on the power and wait for the automatic homing to complete.

5. Open the control software and connect to Carvera Air (please read Carvera Air instruction manual for detailed steps)

6. Open Root->Examples->Rotation in the remote directory.

4th-axis relief

Roughing process :

1. Select "NefertitiRough.nc" roughing file.
2. Open the task configuration and operation dialog box.

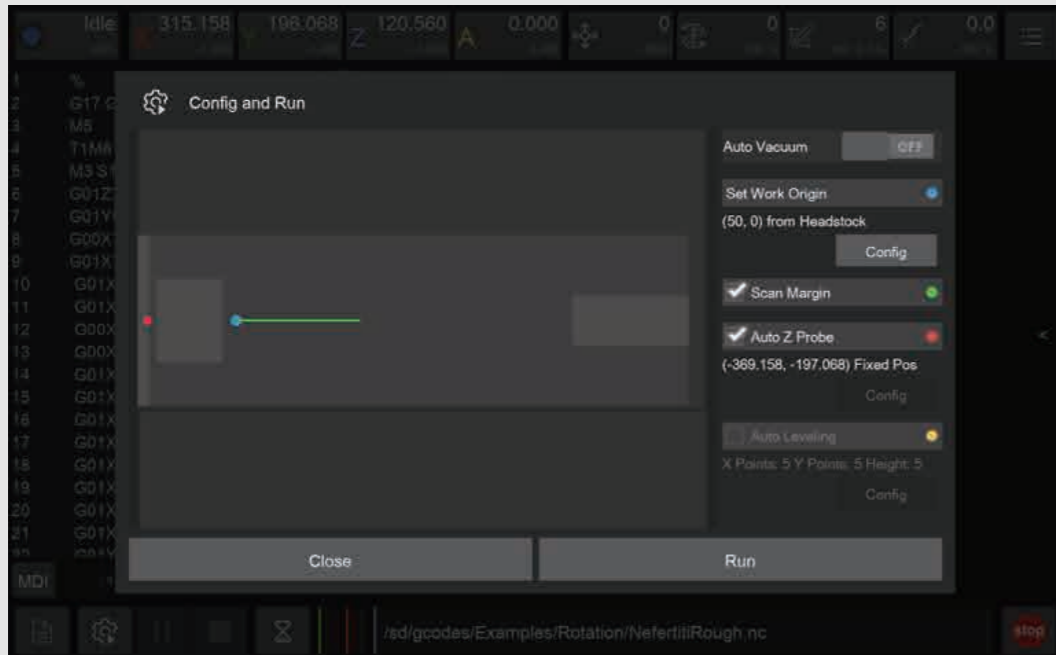

3. Set working coordinate to X offset 50 (relative to the right edge of the 4th axis headstock), and Y offset 0.
4. Check the "Scan Margin" option.
5. Check the "Auto Z Probe" option(4-axis z probe at fixed position, no configuration required).
6. Check the configuration according to the figure above and click Run, change the tools according to the controller software's prompt. (Please refer to Item 6 on Page 9)
7. This step can produce lots of dust, please use a vacuum to clean before next step.

Finishing process :

1. Select "NefertitiFinish.nc" finishing file.
2. Open the task configuration and operation dialog box (the automatic detection has been completed in step 1, no need to redo it here).

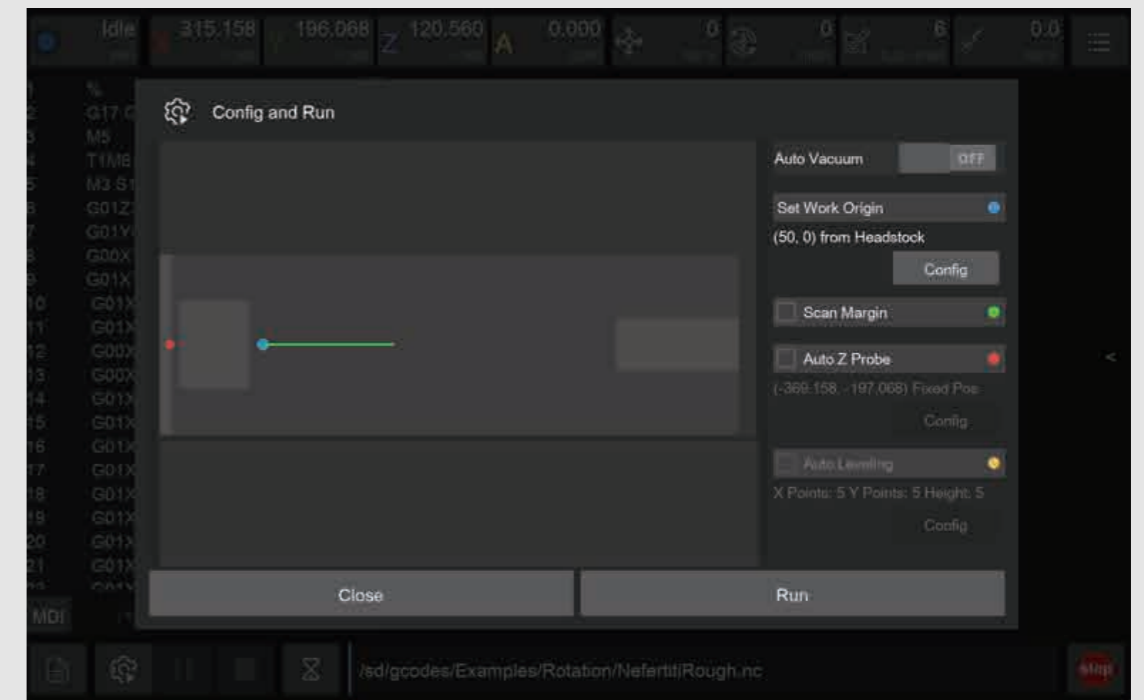

3. Uncheck the "Scan Margin" option.
4. Uncheck the "Auto Z Probe" option.
5. Check the configuration according to the figure above and click Run, change the tools according to the controller software's prompt. (Please refer to Item 6 on Page 9)
6. Use a vacuum to clean up the dust and take out the epoxy tooling board.
7. Use the handsaw in the accessory kit to remove the remaining epoxy on both ends.

Examples Guide | www.makera.com | support@makera.com

